

Robotics 1

July 8, 2024

Exercise 1

Based on the data sheet of the 7R robot shown in Fig. 1, assign the link frames and fill in the associated table of parameters according to the Denavit-Hartenberg (D-H) notation (use the attached sheet). The joint axes are labeled from A1 to A7. Frame 0 and frame 7 are already displayed; the green symbols \otimes and \odot denote here an axis *going in* or, respectively, *coming out* the sheet, so as to complete a right-handed frame. The assignment of the D-H frames should be such that all constant parameters are *non-negative*. Provide the numerical values of all parameters, including those of the joint variables $\theta_i \in (-\pi, \pi]$, for $i = 1, \dots, 7$, in the configuration shown.

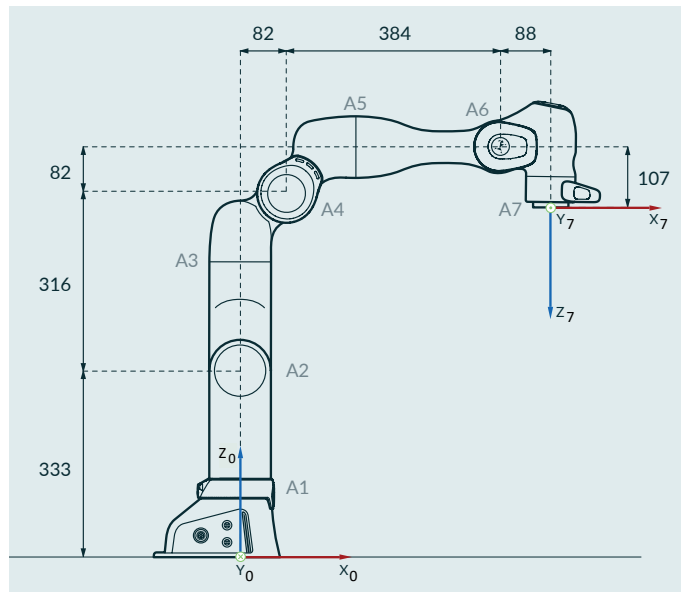

Figure 1: From the data sheet of a 7R robot. Lengths are in [mm].

Exercise 2

In the orientation specified by the rotation matrix

$$\mathbf{R} = \begin{pmatrix} \sqrt{2}/2 & 0 & \sqrt{2}/2 \\ \sqrt{2}/2 & 0 & -\sqrt{2}/2 \\ 0 & 1 & 0 \end{pmatrix},$$

the end effector of a robot has the angular velocity

$$\boldsymbol{\omega} = \begin{pmatrix} 1 \\ 1 \\ 2 \end{pmatrix} \text{ [rad/s]}.$$

Represent the orientation \mathbf{R} with RPY-type angles $\boldsymbol{\phi} = (\alpha, \beta, \gamma)$ around the sequence of fixed axes YZX and provide the value $\dot{\boldsymbol{\phi}}$ that produces the given angular velocity.

Exercise 3

Two equal 2R planar robots with unit length links share a collaborative task. With reference to Fig. 2, the base of robot A is placed at the origin of the world frame while robot B is mounted head down on the line Γ with a base that can slide on it. The line Γ is tilted by an angle $\gamma = 135^\circ$ with respect to the x_w axis and intersects this axis at a distance $\Delta = 4$ m from the origin of the world frame. When robot A is in the configuration $\mathbf{q}_A = (\pi/4, -\pi/3)$ [rad], determine the position of the base of robot B on Γ and its configuration \mathbf{q}_B such that the end effectors of the two robots are in the same position, aligned and facing each other. Is the solution found unique?

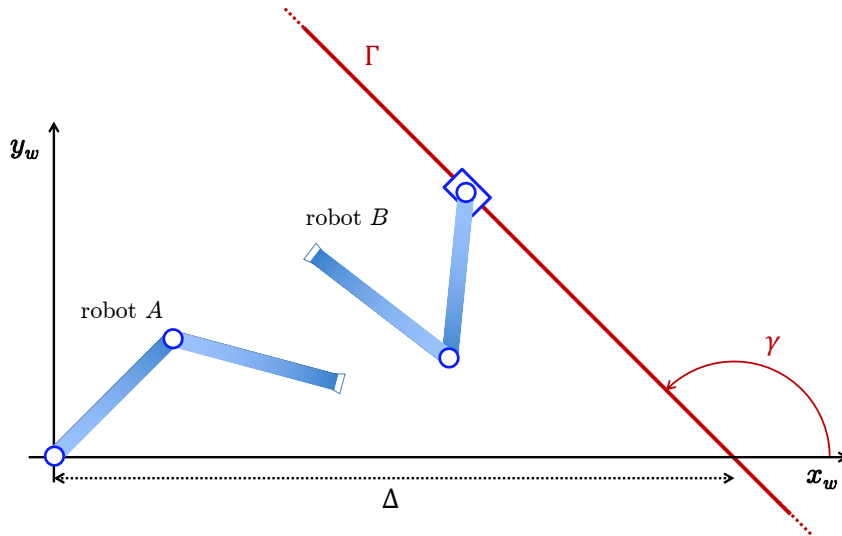

Figure 2: Set-up for the collaborative task.

Exercise 4

Consider a rest-to-rest trajectory planning problem for a RP planar robot. The robot should move its end effector along a linear path between the two Cartesian positions $\mathbf{p}_i = (0.6, -0.3)$ and $\mathbf{p}_f = (-0.3, 0.6)$ [m], using a trapezoidal speed profile. The velocities of the two joints are bounded by $|\dot{q}_1| \leq 2$ rad/s and $|\dot{q}_2| \leq 1$ m/s, while the acceleration along the path is bounded in norm as $\|\ddot{\mathbf{p}}\| \leq A = 0.5$ m/s². What is the minimum feasible motion time T for this task? Provide also the corresponding value of the joint velocity $\dot{\mathbf{q}}$ at the midpoint of the path.

[210 minutes (3,5 hours); open books]

Solution

July 8, 2024

Exercise 1

The 7R robot in Fig. 1 is a Franka Research 3. A correct assignment of D-H frames satisfying the requests is shown in Fig. 3, while Tab. 1 contains the corresponding (non-negative) constant parameters, as well as the values of the joint variables θ in the configuration shown. The axes z_1 , z_3 and z_5 are coming out the sheet (denoted with \odot).

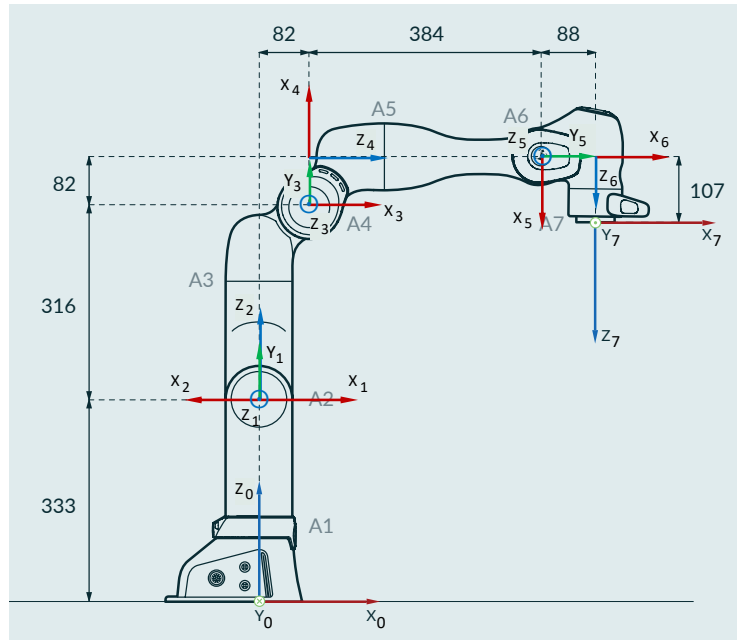

Figure 3: D-H frames for the 7R Franka Research 3 robot.

i	α_i	a_i	d_i	θ_i
1	$\pi/2$	0	333	0
2	$\pi/2$	0	0	π
3	$\pi/2$	82	316	π
4	$\pi/2$	82	0	$\pi/2$
5	$\pi/2$	0	384	π
6	$\pi/2$	88	0	$\pi/2$
7	0	0	107	0

Table 1: D-H parameters for the frame assignment in Fig. 3 (units in [rad] or [mm]).

Exercise 2

The rotation matrix associated to the RPY-type angles $\phi = (\alpha, \beta, \gamma)$ around the sequence of fixed axes YZX is given by

$$\mathbf{R}_{YZX} = \mathbf{R}_X(\gamma)\mathbf{R}_Z(\beta)\mathbf{R}_Y(\alpha) = \begin{pmatrix} c_\alpha c_\beta & -s_\beta & s_\alpha c_\beta \\ c_\alpha s_\beta c_\gamma + s_\alpha s_\gamma & c_\beta c_\gamma & s_\alpha s_\beta c_\gamma - c_\alpha s_\gamma \\ c_\alpha s_\beta s_\gamma - s_\alpha c_\gamma & c_\beta s_\gamma & s_\alpha s_\beta s_\gamma + c_\alpha c_\gamma \end{pmatrix}$$

The inverse relations from an orientation matrix $\mathbf{R} = \{R_{ij}\}$ to (α, β, γ) are given by

$$\beta = \text{atan2} \left\{ -R_{12}, \pm \sqrt{R_{11}^2 + R_{13}^2} \right\} \quad \alpha = \text{atan2} \left\{ \frac{R_{13}}{c_\beta}, \frac{R_{11}}{c_\beta} \right\} \quad \gamma = \text{atan2} \left\{ \frac{R_{32}}{c_\beta}, \frac{R_{22}}{c_\beta} \right\},$$

out of the representation singularity $c_\beta = \sqrt{R_{11}^2 + R_{13}^2} = 0$.

For the given rotation matrix \mathbf{R} , this gives the two regular solutions

$$\phi_1 = \begin{pmatrix} \alpha_1 \\ \beta_1 \\ \gamma_1 \end{pmatrix} = \begin{pmatrix} \pi/4 \\ 0 \\ \pi/2 \end{pmatrix} \quad \phi_2 = \begin{pmatrix} \alpha_2 \\ \beta_2 \\ \gamma_2 \end{pmatrix} = \begin{pmatrix} -3\pi/4 \\ \pi \\ -\pi/2 \end{pmatrix}.$$

The contributions of the three time derivatives $\dot{\alpha}$, $\dot{\beta}$ and $\dot{\gamma}$ to $\boldsymbol{\omega}$ when the orientation is ϕ is computed as¹

$$\boldsymbol{\omega} = \boldsymbol{\omega}_\gamma + \boldsymbol{\omega}_\beta + \boldsymbol{\omega}_\alpha = \begin{pmatrix} 1 \\ 0 \\ 0 \end{pmatrix} \dot{\gamma} + \mathbf{R}_X(\gamma) \begin{pmatrix} 0 \\ 0 \\ 1 \end{pmatrix} \dot{\beta} + \mathbf{R}_X(\gamma)\mathbf{R}_Z(\beta) \begin{pmatrix} 0 \\ 1 \\ 0 \end{pmatrix} \dot{\alpha}$$

and thus $\boldsymbol{\omega} = \mathbf{T}(\beta, \gamma)\dot{\phi}$ with

$$\mathbf{T}(\beta, \gamma) = \begin{pmatrix} -s_\beta & 0 & 1 \\ c_\beta c_\gamma & -s_\gamma & 0 \\ c_\beta s_\gamma & c_\gamma & 0 \end{pmatrix}.$$

Note that $\det \mathbf{T}(\beta, \gamma) = c_\beta$ vanishes exactly at the singularity of the YZX RPY-type representation. Evaluating \mathbf{T} for the two solution triples ϕ_1 and ϕ_2 gives

$$\mathbf{T}_1 = \mathbf{T}(\beta_1, \gamma_1) = \begin{pmatrix} 0 & 0 & 1 \\ 0 & -1 & 0 \\ 1 & 0 & 0 \end{pmatrix} \quad \mathbf{T}_2 = \mathbf{T}(\beta_2, \gamma_2) = \begin{pmatrix} 0 & 0 & 1 \\ 0 & 1 & 0 \\ 1 & 0 & 0 \end{pmatrix}.$$

Accordingly, we have the two solutions

$$\dot{\phi}_1 = \mathbf{T}_1^{-1}\boldsymbol{\omega} = \begin{pmatrix} 2 \\ -1 \\ 1 \end{pmatrix} \quad \dot{\phi}_2 = \mathbf{T}_2^{-1}\boldsymbol{\omega} = \begin{pmatrix} 2 \\ 1 \\ 1 \end{pmatrix}.$$

¹An alternative but more lengthy way would be to use the relationship $\dot{\mathbf{R}}(\phi)\mathbf{R}^T(\phi) = \mathbf{S}(\boldsymbol{\omega})$, and then extracting from the off-diagonal elements of the skew-symmetric matrix \mathbf{S} the components ω_x , ω_y and ω_z . Also, the elements of matrix \mathbf{R} have a linear dependence on the components $\dot{\alpha}$, $\dot{\beta}$ and $\dot{\gamma}$ of $\dot{\phi}$.

Exercise 3

The problem involves the use of a suitable homogeneous transformation between the base frames of the two robots and can be solved in different ways. The following is a simple one.

Through its direct kinematics, the end-effector position of robot A for $\mathbf{q}_A = (\pi/4, -\pi/3)$ [rad] is

$${}^w \mathbf{p}_A = \mathbf{f}_A(\mathbf{q}_A) = \begin{pmatrix} \cos q_{A1} + \cos(q_{A1} + q_{A2}) \\ \sin q_{A1} + \sin(q_{A1} + q_{A2}) \end{pmatrix} = \begin{pmatrix} 1.6730 \\ 0.4483 \end{pmatrix} \text{ [m]}.$$

as expressed in the world frame, which coincides with the base frame of robot A . Robot B should place its end effector in this same position, facing the end effector of robot A and with an orientation that is aligned with the second link of this robot. Thus, it is convenient to *extend* the robot A by adding to its second link also the length of the second link of robot B (all links have unit length), namely with the modified direct kinematics

$${}^w \mathbf{p}_E = \begin{pmatrix} \cos q_{A1} + 2 \cos(q_{A1} + q_{A2}) \\ \sin q_{A1} + 2 \sin(q_{A1} + q_{A2}) \end{pmatrix} = \begin{pmatrix} 2.6390 \\ 0.1895 \end{pmatrix} \text{ [m]}.$$

The position \mathbf{p}_E is shown in Fig. 4. This point should be the target for the tip of the first link of robot B , without further conditions on the orientation part of the collaborative task (already satisfied by the ‘trick’ of extending the second link of robot A). Accordingly, the robot B mounted on a sliding base and taken up to the tip of the first link can be seen as an equivalent PR robot with a fixed base placed at the intersection between the line Γ and the world axis x_w .

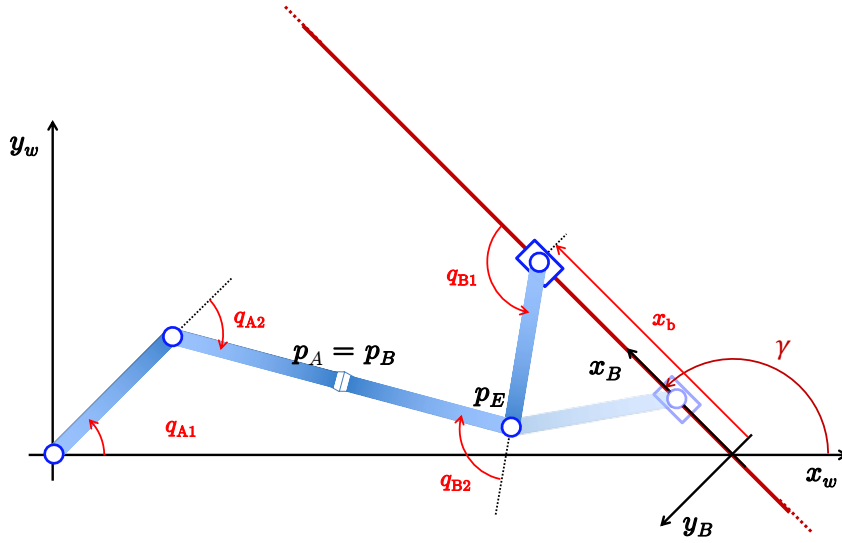

Figure 4: Graphical illustration of the two solutions for the collaborative task.

Place then the base frame of robot B as in Fig. 4. The homogeneous transformation² between the

²Since the problem is planar, we will use here a 3×3 homogeneous matrix, with a 2×2 rotation matrix $\mathbf{R} \in SO(2)$ and a position vector $\mathbf{p} \in \mathbb{R}^2$.

base frames $A (\equiv w)$ and B is then

$${}^w\mathbf{T}_B = {}^A\mathbf{T}_B = \begin{pmatrix} \cos \gamma & -\sin \gamma & \Delta \\ \sin \gamma & \cos \gamma & 0 \\ 0 & 0 & 1 \end{pmatrix} = \begin{pmatrix} -\sqrt{2}/2 & -\sqrt{2}/2 & 4 \\ \sqrt{2}/2 & -\sqrt{2}/2 & 0 \\ 0 & 0 & 1 \end{pmatrix}.$$

As a result, we compute

$$\begin{aligned} {}^B\mathbf{p}_{E,hom} &= {}^B\mathbf{T}_w {}^w\mathbf{p}_{E,hom} = {}^w\mathbf{T}_B^{-1} \begin{pmatrix} {}^w\mathbf{p}_E \\ 1 \end{pmatrix} \\ &= \begin{pmatrix} -\sqrt{2}/2 & \sqrt{2}/2 & 2.8284 \\ -\sqrt{2}/2 & -\sqrt{2}/2 & 2.8284 \\ 0 & 0 & 1 \end{pmatrix} \begin{pmatrix} 2.6390 \\ 0.1895 \\ 1 \end{pmatrix} = \begin{pmatrix} 1.0964 \\ 0.8284 \\ 1 \end{pmatrix} = \begin{pmatrix} {}^B\mathbf{p}_E \\ 1 \end{pmatrix}. \end{aligned}$$

The direct kinematics of the equivalent PR robot is simply

$${}^B\mathbf{p}_{Beq} = \mathbf{f}_{PR}(x_b, q_{B1}) = \begin{pmatrix} x_b + \cos q_{B1} \\ \sin q_{B1} \end{pmatrix}.$$

The inverse kinematics is given by

$$x_b = {}^B\mathbf{p}_{Beq,x} \pm \sqrt{1 - ({}^B\mathbf{p}_{Beq,x})^2} \quad q_{B1} = \text{atan2} \{ {}^B\mathbf{p}_{Beq,y}, {}^B\mathbf{p}_{Beq,x} - x_b \}.$$

The joint angle q_{B2} of robot B is found by setting the difference between the absolute orientations of the two end effectors so that they face each other; i.e., the difference should be equal to π :

$$(\gamma + q_{B1} + q_{B2}) - (q_{A1} + q_{A2}) = \pi \quad \Rightarrow \quad q_{B2} = q_{A1} + q_{A2} + \pi - (\gamma + q_{B1}).$$

Setting now ${}^B\mathbf{p}_{Beq} = {}^B\mathbf{p}_E = (1.0964, 0.8284)$ [m], two solutions are found, as sketched graphically in Fig. 4; one solution is closer to the base frame of robot B

$$x_b = 0.6037 \text{ m} \quad \mathbf{q}_B = \begin{pmatrix} 1.0343 \\ -0.5107 \end{pmatrix} \text{ [rad]},$$

while the other is further away

$$x_b = 1.8647 \text{ m} \quad \mathbf{q}_B = \begin{pmatrix} 2.3186 \\ -1.7950 \end{pmatrix} \text{ [rad]}.$$

Exercise 4

The RP planar robot³ and the desired motion task are shown in Fig. 5. The linear path has length $L = \|\mathbf{p}_f - \mathbf{p}_i\| = 1.2728$ m and is traced by

$$\mathbf{p}(s) = \mathbf{p}_i + s \frac{\mathbf{p}_f - \mathbf{p}_i}{L} \quad s \in [0, L],$$

where s is the path parameter (here, the arc length). The timing law $s(t)$, for $t \in [0, T]$, should have a rest-to-rest (symmetric) trapezoidal profile for the speed \dot{s} , which is fully described by the

³This is by default the most common structure of a PR planar robot. Moreover, we shall assume that $q_2 > 0$.

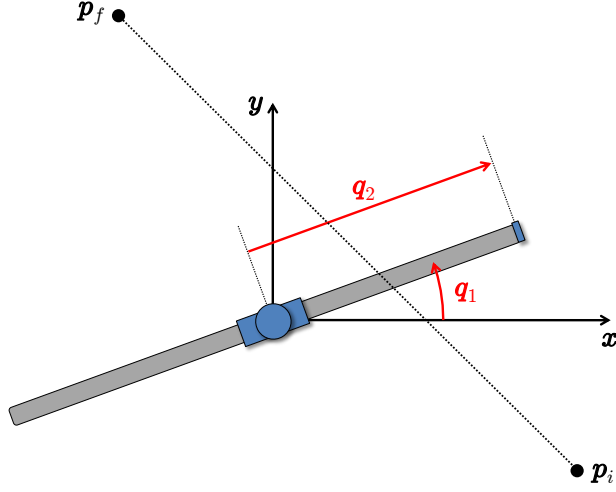

Figure 5: Trajectory planning task for a RP robot.

cruising speed V along the path and by the acceleration A in the first phase (with a rise time $T_r = V/A$). The Cartesian velocity and acceleration of the robot end effector are, respectively,

$$\dot{\mathbf{p}} = \frac{\mathbf{p}_f - \mathbf{p}_i}{L} \dot{s} \quad \ddot{\mathbf{p}} = \frac{\mathbf{p}_f - \mathbf{p}_i}{L} \ddot{s}.$$

While we have for the acceleration norm $\|\ddot{\mathbf{p}}\| = |\ddot{s}| \leq A = 0.5 \text{ m/s}^2$, there is instead no explicit bound specified in the Cartesian space for the velocity norm $\|\dot{\mathbf{p}}\| = |\dot{s}| \leq V$. This should be derived from the available velocity limits in the joint space.

Note first that, using the inverse kinematics of the RP robot

$$q_1 = \text{atan2}\{p_y, p_x\} \quad q_2 = \|\mathbf{p}\| = \sqrt{p_x^2 + p_y^2},$$

we obtain from the initial and final Cartesian points \mathbf{p}_i and \mathbf{p}_f

$$\mathbf{q}_i = \begin{pmatrix} -0.4636 \\ 0.6708 \end{pmatrix} [\text{rad}, \text{m}] \quad \mathbf{q}_f = \begin{pmatrix} 2.0344 \\ 0.6708 \end{pmatrix} [\text{rad}, \text{m}].$$

The revolute (first) joint has to travel by $\Delta q_1 = q_{f,1} - q_{i,1} = 2.4981 \text{ rad}$. Therefore, its motion time is lower bounded by $|\Delta q_1|/V_1 = 1.2490 \text{ s}$ (assuming an infinite joint acceleration). Moreover, the joint value at the midpoint is $q_{m,1} = (q_{i,1} + q_{f,1})/2 = 0.7854 \text{ rad}$. On the other hand, since $q_{f,2} = q_{i,2} = 0.6708$, the prismatic (second) joint needs first to reduce its length in order to remain on the linear Cartesian path, and then to reverse motion increasing the length back to the initial value in a symmetric way with respect to the path midpoint; the minimum extension will be at $\mathbf{p}_m = (\mathbf{p}_i + \mathbf{p}_f)/2 = (0.15, 0.15) \text{ m}$, corresponding to $q_{m,2} = 0.2121 \text{ m}$. Therefore, the motion time of the second joint is lower bounded by $(|q_{m,2} - q_{i,2}| + |q_{f,2} - q_{m,2}|)/V_2 = 0.9174 \text{ s}$ (assuming again an infinite joint acceleration).

The above analysis shows that the limiting velocity factor is due to the revolute joint. As a result, we can take as upper bound for the Cartesian speed along the path the worst case situation, namely when the distance to the path is minimum, i.e., at $q_{m,2} = 0.2121 \text{ m}$, and evaluate

$$|\dot{s}| \leq V = q_{m,2} \cdot V_1 = 0.4243 \text{ m/s}.$$

With L , V , and A , we compute the minimum feasible motion time along the linear path when using a trapezoidal profile⁴ as

$$T = \frac{LA + V^2}{VA} = \frac{L}{V} + \frac{V}{A} = 3.8485 \text{ s.}$$

To evaluate the joint velocity $\dot{\mathbf{q}}$ at the path midpoint (corresponding to $\mathbf{q}_m = (0.7854, 0.2121)$ [rad,m]), we need the task Jacobian for this robot:

$$\mathbf{J}(\mathbf{q}) = \begin{pmatrix} -q_2 \sin q_1 & \cos q_1 \\ q_2 \cos q_1 & \sin q_1 \end{pmatrix} \Rightarrow \mathbf{J}_m = \mathbf{J}(\mathbf{q}_m) = \begin{pmatrix} -0.15 & \sqrt{2}/2 \\ 0.15 & \sqrt{2}/2 \end{pmatrix}.$$

Being $\dot{\mathbf{p}}_m = V(\mathbf{p}_f - \mathbf{p}_i)/L = (-0.3, 0.3)$ [m/s] (the speed at the path midpoint is certainly at the cruise value), we have as expected

$$\dot{\mathbf{q}}_m = \mathbf{J}_m^{-1} \dot{\mathbf{p}}_m = \begin{pmatrix} 2 \\ 0 \end{pmatrix} \text{ [rad, m].}$$

Figure 6 shows the components of the planned trajectory in the Cartesian space and of the corresponding trajectory in the joint space, together with their velocity and acceleration.

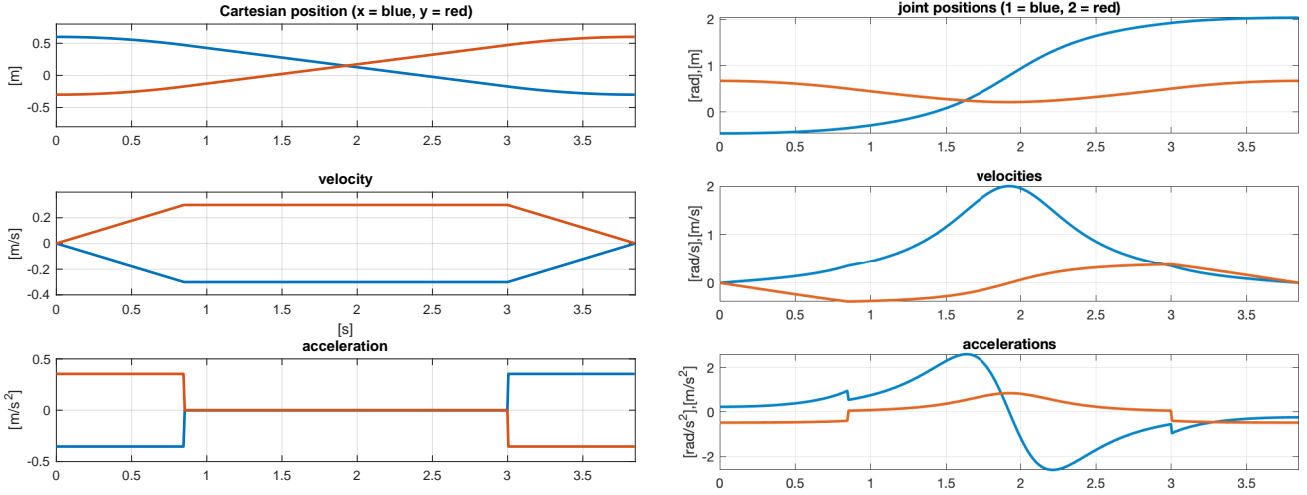

Figure 6: *Left:* The components of the minimum-time Cartesian trajectory using a trapezoidal speed profile. *Right:* The components of the corresponding joint trajectory.

* * * * *

⁴Since $L > V^2/A$, the existence of a motion phase at cruise speed V is guaranteed.