

Assignment of DH frames and associated table of parameters

Name: _____

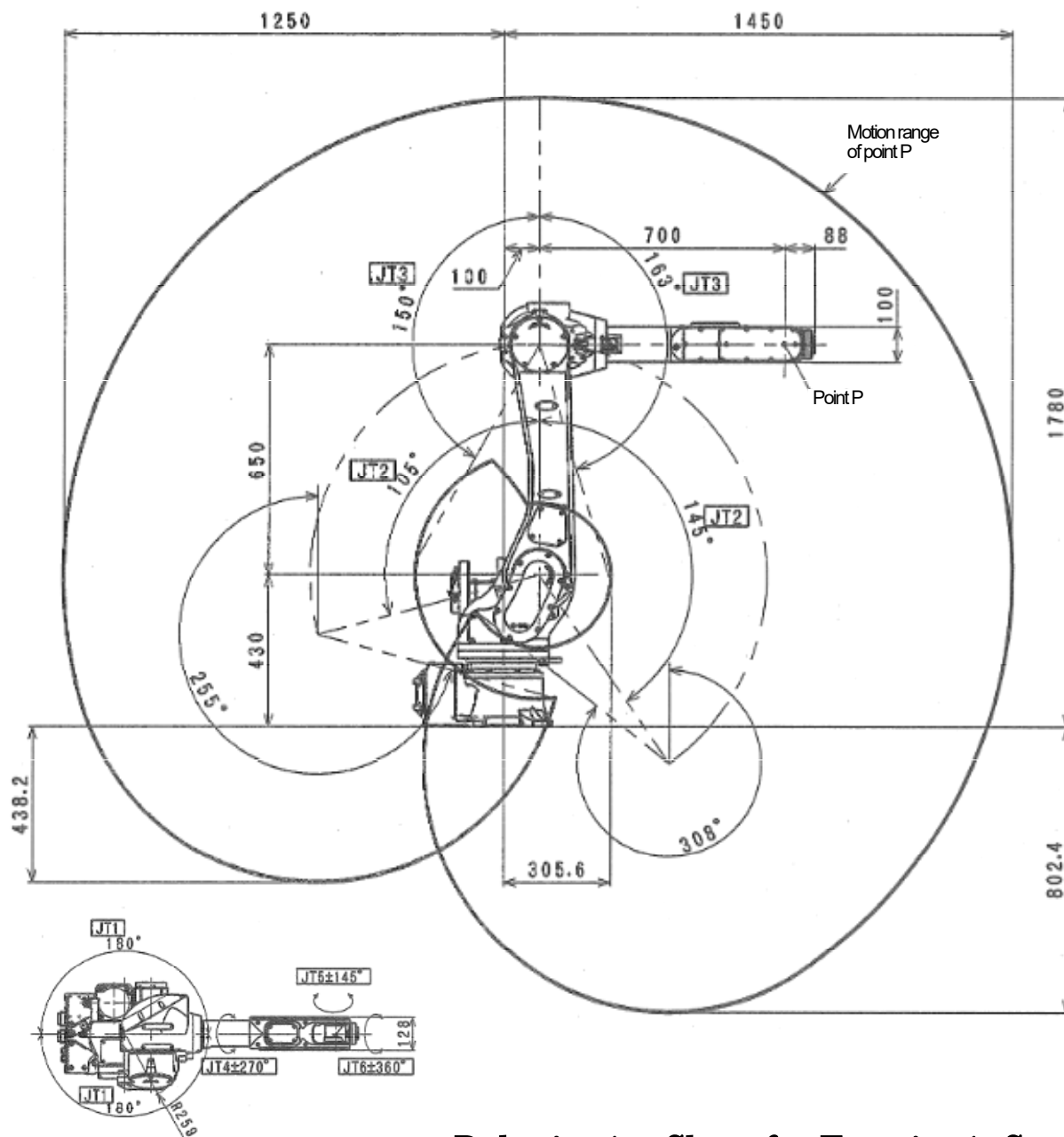

i	α_i	a_i	d_i	θ_i
1				
2				
3				
4				
5				
6				

